

Clark

32" Landscape Wall-Mounted Touchscreen

The Clark series of ALICE Receptionist displays are professional-grade large format wall mounted displays in a slim, integrated package.

This high-quality, interactive canvas is designed from the bottom-up for attracting and engaging consumers in retail, hospitality, healthcare and other commercial markets.

The 32" Clark screen provides companies an attractive, affordable commercial grade display that is easy to install.

SPECIFICATIONS

- 32" LCD touchscreen monitor
- Landscape configuration
- Internal computer module
- Attached echo cancelling mic / speaker (not shown)
- Attached web camera (not shown)





TOTAL THICKNESS
INCLUDING BRACKET
IR = 100.1
PCAP = 89

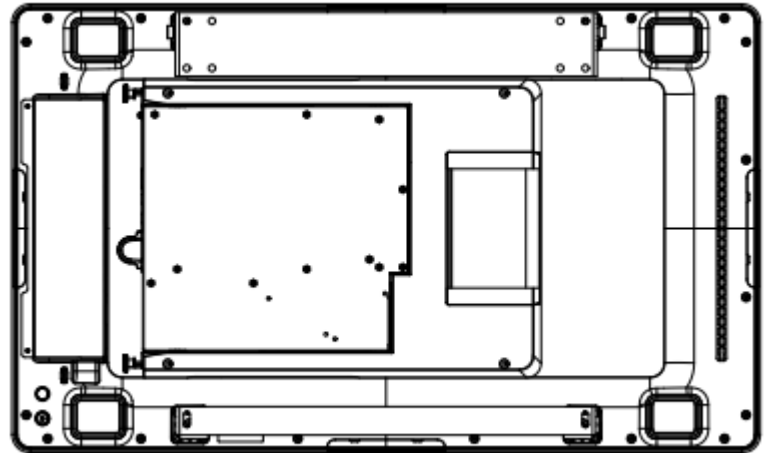
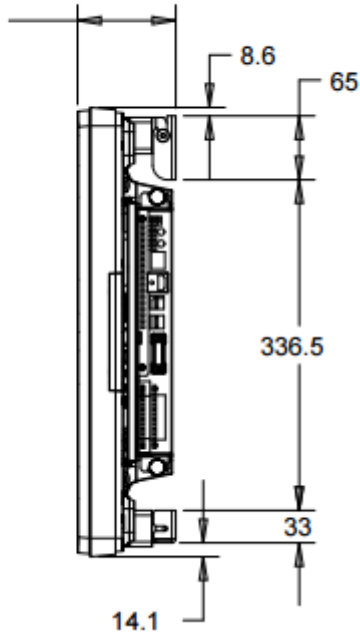

Full mounting instructions can be provided on request

COMPUTER MODULE

- 3 year warranty
- 3.7 GHz Intel Core i5 Processor
- 4GB RAM
- 320GB HDD
- Windows 7 Professional
- LAN (Gigabit Ethernet)

MONITOR

- 3 year warranty with on-site exchange
- Resolution: 1920 x 1080 @ 60hz
- Horizontal / Vertical Viewing Angle: $\pm 89^\circ$ or 178°
- 120V at 60hz: On: 55W; Sleep: 9W; Off: 2W
- Input voltage: 100 – 240 VAC 50/60hz
- MTBF: 50,000 hours
- Response time: 8 ms
- Contrast ratio: 3000:1
- Display colors: 16.7 million
- Enclosure color: Black

SHIPPING

- Monitor Dimensions (Packaged): 34.8" x 7.9" x 22.8" / 885 mm x 200 mm x 580 mm
- Module Dimensions (Packaged): 21" x 16.5" x 5.12" / 419 mm x 535 mm x 130 mm
- Monitor Weight (Packaged): 39.88 lbs / 18.09 kg
- Module Weight (Packaged): 10.75 lbs / 4.88 kg

WinTech LLC
sales@ALICEreceptionist.com • (702) 284-7375